

## INV-7500ES

14HP / 459cc 7.5kw 240V INVERTER GENERATOR

# OPERATOR'S MANUAL



Read this manual carefully before operation.  
This manual includes important guidance for safety operation.



This Manual contains important safety information and instructions for operating this generating set. **PLEASE READ THIS MANUAL CAREFULLY.** Failure to do so could result in property damage and/or personal INJURY/DEATH.

Provide this manual to any operator of this generating set. This manual should be considered as a permanent part of your generating set and should remain with it when you sell it.

All pictures & figures are only one example of series generating set. It shall be only for reference and perhaps there will be difference between pictures & figures and physical products.

All information in this publication is based on the latest product information available at the time of printing. We reserve the right to change, alter and/or improve the product and this document at any time without notice and without incurring any obligation.

No part of this publication shall be reproduced without written permission.

Write down the generating set's serial number and purchase information. Keep this manual and the receipt for future reference.

Model:

---

Serial number:

---

Date of purchase:

---

# Contents

<b>I. Operator safety</b> .....	<b>1</b>
1. Safety rules .....	1
<b>II. Getting started</b> .....	<b>6</b>
1. Unpacking.....	6
2. Assembly.....	6
3. Features and Controls.....	9
<b>III. Operating</b> .....	<b>13</b>
1. Operating checklist .....	13
2. Starting the generating set.....	18
3. Connect to electrical devices .....	21
4. Stopping the generating set.....	23
<b>IV. Maintenance</b> .....	<b>25</b>
1. Maintenance schedule .....	25
2. Generating set maintenance.....	26
3. Engine maintenance .....	27
<b>V. Trouble-shooting</b> .....	<b>31</b>
<b>VI. Storage and transportation</b> .....	<b>33</b>
<b>VII. Specification</b> .....	<b>34</b>
1. Specification parameter table .....	34
2. Wiring diagram .....	35

# I. Operator safety

## 1. Safety rules



Pay attention to this safety alert symbol. Obey all safety messages that followed by this symbol to avoid possible property damage, INJURY or DEATH.

Each safety message is preceded by a safety alert symbol and one of three words, DANGER, WARNING, or CAUTION.

### **DANGER**

Indicates a hazardous situation which, if not strictly complied with, will result in substantial property damage, serious injury or DEATH.

### **WARNING**

Indicates a hazardous situation which, if not strictly complied with, may result in property damage, serious injury or DEATH.

### **CAUTION**

Indicates a hazardous situation which, if not strictly complied with, could result in property damage or injury.



### **WARNING**

**READ THIS MANUAL COMPLETELY BEFORE OPERATING.**

DO NOT operate this generating set until you have read ALL safety, Operation, and maintenance instructions listed in this manual.

**Failure to follow the instructions may result in property damage, INJURY or DEATH.**

The warnings and precautions discussed in this manual cannot cover all possible conditions and situations that may occur. It must be understood by the operator that common sense and caution are factors which cannot be built into this product, but must be possessed by the operator.

### **WARNING**

This generating set is intended for residential consumer use only.

Air cooled generating sets cannot be run full time.

No personal-modified any part of the generating set or any unsuitable usage is allowed.



## **⚠ DANGER**

### **TOXIC FUMES**

The exhaust of the engine contains carbon monoxide, an odorless, colorless, poison gas. Using engine indoors **CAN KILL YOU!**

**NEVER** use inside any building or any kind of enclosure, **EVEN IF** doors and windows are open.

Place the engine in a well-ventilated area and carefully consider wind and air currents when positioning the engine.



## **⚠ WARNING**

### **FIRE**

Operation of this engine may create sparks that can start fires around flammable material.

This engine may not be equipped with a spark arresting muffler. If the engine will be used around flammable materials, or on land covered with materials such as agricultural crops, forest, brush, grass, or other similar items, then an approved spark arrester must be installed.

In some area, a spark arrester is required by law.

Please contact local fire agencies for laws or regulations relating to fire prevention requirements.

## **⚠ WARNING**

### **BATTERY ACID**

Be careful when using any battery, the battery must be kept away from heat, sparks or open flames.

The battery emits hydrogen gas (harmful to human body) when charging. Please charge the battery in a well-ventilated place to avoid battery acid overflow. If battery acid comes into contact with skin, rinse immediately with clean water.



Flammable materials can catch fire when they come into contact with hot surfaces. Do not place flammable objects within 1.5 meters.



**⚠ WARNING**

### **HOT SURFACE**

Running engines produce heat. Severe burns can occur on contact.

**DO NOT** touch engine while operating or just after stopping. Avoid contact with hot exhaust gases.



**⚠ DANGER**

### **FIRE OR EXPLOSION**

Petrol is highly flammable and extremely explosive.

Fire or explosion can cause severe burns or death.

Keep flammable items away while handling gasoline.

Fill fuel tank outdoors and in a well-ventilated area with the engine stopped.

Always wipe off spilled fuel and wait until the fuel has dried before starting the engine.

**DO NOT** operate the engine with known leaks in the fuel system.

Use proper fuel storage and handling procedures.

**DO NOT** store fuel or other flammable materials nearby.

Empty the fuel tank before storing or transporting this generating set!

Keep fire extinguisher handy and be prepared if a fire starts.



**⚠ DANGER**

### **ELECTRIC SHOCK**

This generating set produces powerful voltage and the electricity **CAN KILL YOU**.

This generating set must be properly connected to an appropriate ground to help prevent electric shock.

Failure to properly ground generating set can result in electrocution, especially if the generating set is equipped with a wheel kit.

Consult an electrician for local grounding requirements.

Installation should be performed by a certified electrician.

Improper Installation can result in electric shock and death.

To reduce the risk of electric shock. **DO NOT** use electrical cords that are worn, frayed, bare or otherwise damaged.

**DO NOT** touch bare wires or receptacles.

**DO NOT** operate generating set in wet weather. Keep the generating set dry.

**DO NOT** handle generating set or electrical cords while standing in water, while barefoot, or while hands or feet are wet.

Keep children or pets away from the generating set.

**DO NOT** hook up any generating set to a building's electrical system without the proper use and installation of a transfer switch installed by a qualified electrician.

When using generating set for backup power, notify utility company. Use approved transfer generating set to isolate generating set from electric utility.

Failure to isolate generating set from power utility can result in death or injury to electric utility workers due to backfeed of electrical energy.



**⚠ WARNING**

### **KICKBACK**

Rapid retraction of the starter cord will pull hand and arm towards the engine faster than you can let go.

Unintentional startup can result in accident.



 **WARNING**

Before each use, check for loose or damaged parts, signs of oil or fuel leaks, and any other condition that may affect proper operation.

Repair or replace all damaged or defective parts immediately.

Locate all operating controls and safety labels.

Make sure all the safety instructions are in right and working condition. Operate only on level surfaces.

DO NOT expose generating set to excessive moisture, dust, or dirt.

Keep all safety guards in place and in proper working order at all times.

DO NOT allow any material to block the cooling slots.

DO NOT allow children or untrained persons to operate the generating set.

DO NOT run the generating set unattended. Turn off the generating set before leaving the area.

Allow 0.9 meter of space around the generator to ensure good cooling.

## II. Getting started

### 1. Unpacking

#### *Remove the Generator from the Shipping Carton*

1. Place the shipping carton on a solid, flat surface.
2. Carefully cut each corner of the carton box from top to bottom. Fold each side flat on the ground.
3. Remove everything from the carton except the generator.

### 2. Assembly

#### 1 Assemble wheels

After fixing the wheel axle assembly on the frame, install the wheels and spacers on the wheel axle assembly in turn, and fix it with bolts.

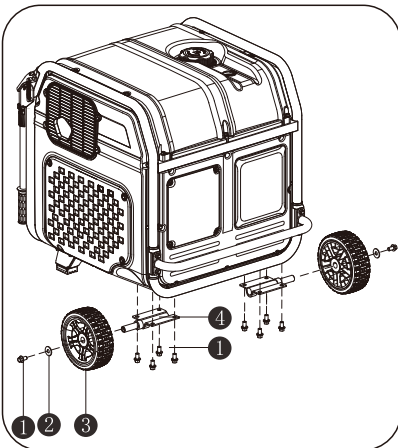

- 1 Bolt M8X14
- 2 washer
- 3 wheel
- 4 wheels axle assembly

#### 2 Install the support feet

Align the mounting holes of the support feet with the mounting holes of the rack, and fasten the support feet to the rack with bolts.

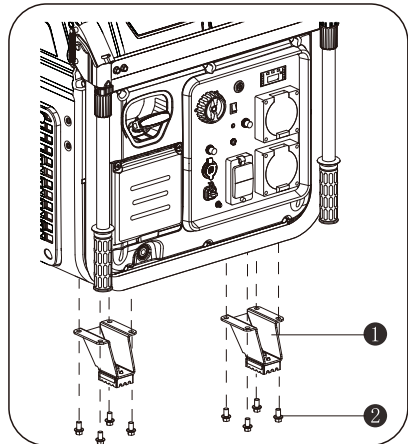

- 1 Support feet assembly
- 2 Bolt M8x14

#### 3 Assemble rear armrest

After aligning the rear armrest mounting holes with the generator mounting holes, fasten them with bolts.

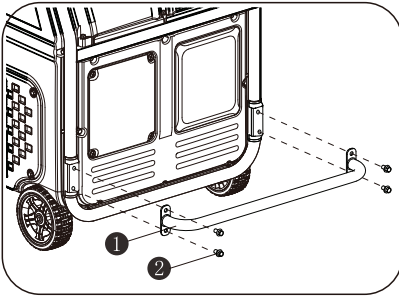

- ① Rear armrest ② Bolt M8x14

#### 4 Install handle

Align the handle and the nylon washer of the brake pin with the mounting hole of the push handle, and then install the washer and retaining ring after the pin is passed through.

The installation steps of the handle rack are the same as above. After installation, hang the two ends of the brake spring on the handle rack and the handle respectively.

The handle connecting bar is installed on the inner side of the handle and fixed with bolts.

- ① Pin
- ② Armrest pendant (left)
- ③ Nylon washers
- ④ Washer
- ⑤ Retaining ring
- ⑥ Spring
- ⑦ Handle assembly (left)
- ⑧ Handle assembly (right)
- ⑨ Armrest rack (right)
- ⑩ Handle connecting bar
- ⑪ Bolt M6 X12

#### ⑫ Nut M6

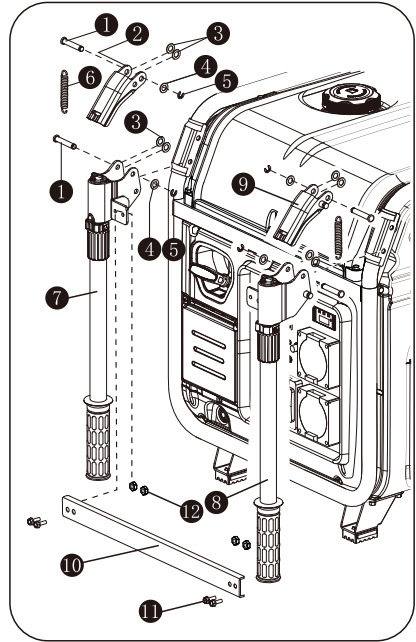

#### 5 Handle operation

The handle can be unfolded by directly lifting it up, and the handle has a self-locking function. After the handle is fully lifted, the position of the handle will be locked and will not fall freely.

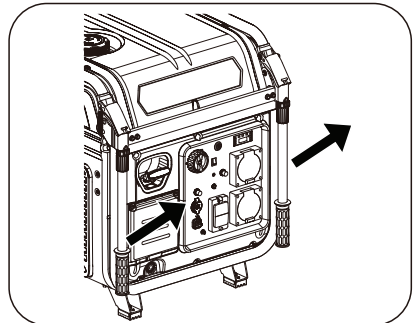

Before lowering the handle, gently lift it up, and turn the rotation sleeve of the handle inward and press to lower the handle.

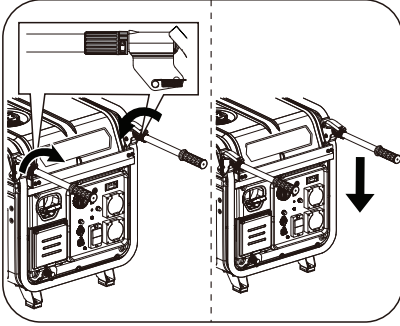

Lift unit up by the frame with 2 people and move to the desired location.



## 6 Moving the Generator

### **⚠ WARNING**

Failure to follow these instructions could result in personal injury or damage to the generator.

### **⚠ CAUTION**

ALWAYS turn the generator off and ensure the fuel valve is closed.

ALWAYS make sure engine and muffler are cooled down before the generator can be handled safely (typically 15-30 minutes).

Do not drop or strike unit or place under heavy objects.

### 3.Features and Controls

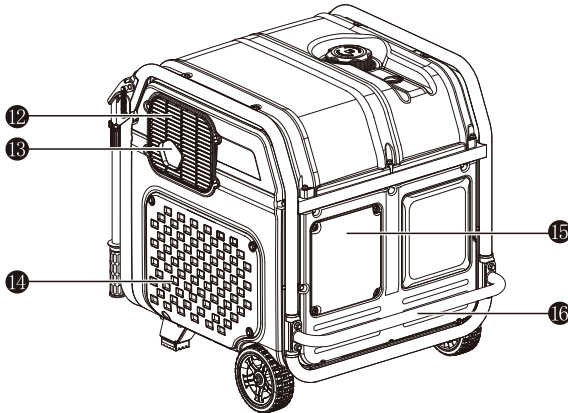
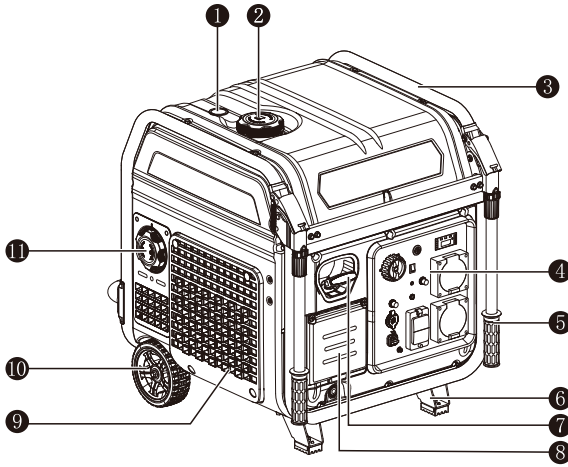

- |                             |                                |
|-----------------------------|--------------------------------|
| ① Lever indicator           | ⑩ Wheel                        |
| ② Fuel cap                  | ⑪ Air filter maintenance cover |
| ③ Rack                      | ⑫ Muffler blind window         |
| ④ Control panel             | ⑬ Muffler                      |
| ⑤ Push handle               | ⑭ Oil drain cover              |
| ⑥ Support feet assembly     | ⑮ Oil maintenance cover        |
| ⑦ Recoil starter            | ⑯ Rear armrest                 |
| ⑧ Battery maintenance cover |                                |
| ⑨ Engine inlet shutter      |                                |

## Control Panel

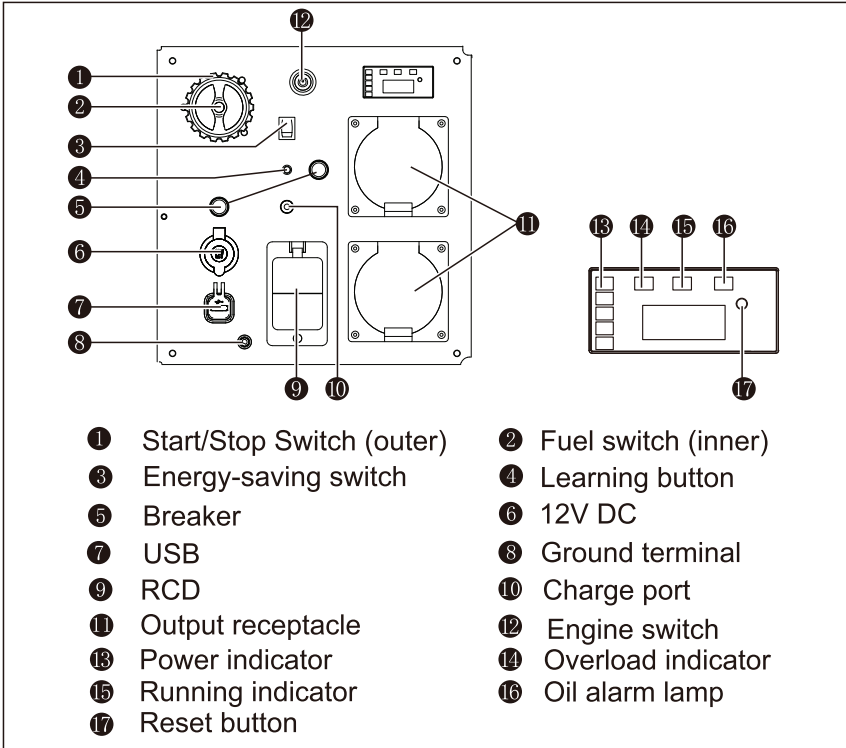

**Fuel switch (inner)**  
**Start stop switch (outer)**

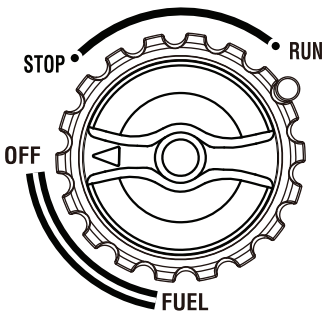

**Fuel switch:** fuel ON/OFF  
**Start/stop switch:** STOP/RUN

**Overload indicator (red)**

The overload indicator light is on, indicating that the generator has detected the output of the connected electrical equipment has exceeded the load capacity of the generator. At this time, stop the generator to protect the generator and the electrical equipment connected. The running indicator (green) goes out, the overload indicator (red) flashes for 3 seconds/time, but the generator will not stop running.

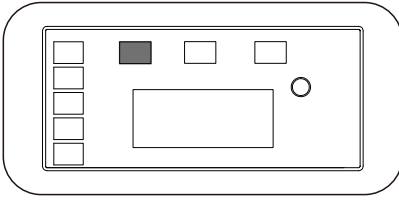

When the generating set has no output and the overload indicator is on, please take the following steps:

1. Lower the total power of the connected electric devices to the rated output range of generating set.
2. Check the air intake for impurities and check the control parts for abnormal situation. Handle immediately if necessary.
3. Press the reset button.

### Running indicator (green)

The running indicator lights up when generating set starts and has normal output.

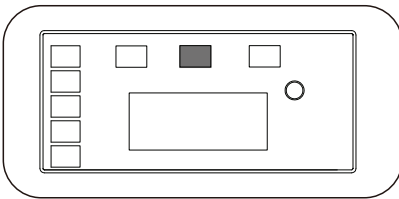

### Oil alarm lamp (yellow)

When the oil level drops below the lower limit, the oil protection system will stop the engine automatically and oil alarm lamp will blink by pulling the recoil starter. The engine will not run until the oil has been filled to the proper level.

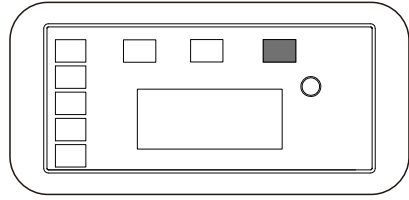

**Note:** If the generator fails to start when the engine is turned off, please turn the start-stop knob to the "RUN" position, and then pull the starter handle. If the oil alarm indicator lights up, it means that the oil capacity is insufficient, please add oil and restart.

### Reset button

The reset button is used to restore output if an overload occurs. To restore output, reduce the loads and press the reset button.

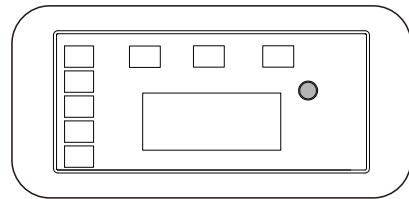

### Energy-saving switch

When the electrical equipment needs a large starting current, please put the energy-saving switch in the "OFF" position.

While when the electrical equipment needs a small starting current, please put the energy-saving switch in the "ON" position.

**Note:** When using equipment with large starting current (as air compressors, submerged water pumps, etc.), please put the energy-saving switch in the “OFF” position.

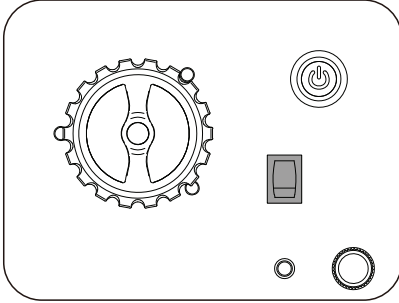

### Ground terminal

The grounding terminal is designed to prevent electric shock by connecting it to the grounding wire. The generating set must be properly grounded before operation.

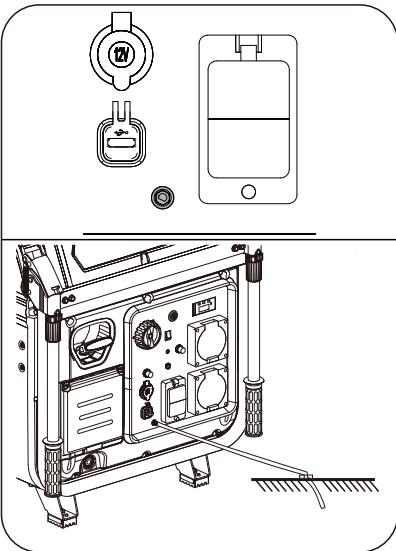

### Over-current Protector (Breaker)/Circuit Breaker

When generator is overloaded or overheated for a long time, the over-current protector will protect the output. If it is protected, please lower the load or run without load for a few minutes, and then press the button of the over-current protector to restore the output.

**Note:** Similar to the circuit breaker, flip the switch upward to restore the output.

**Note:** The over-current protector/circuit breaker will be affected by factors such as operating current and ambient temperature, so there will be differences in the protection time.

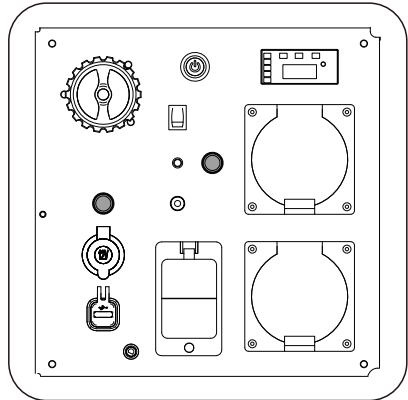



### III. Operating

#### 1. Operating checklist

##### 1 Operating Location

Only use OUTSIDE and place the generating set in a well-ventilated area.

The generator must be placed on a solid, flat surface for operation, and the surrounding environment should be clean, dry, and well ventilated.

Allow two feet clearance on all side of the generating set while operating it outdoors.

Operate in specified area, if any problem on applicable occasion please consult the authorized local dealers. In some areas, generating set must be registered with the local utility. Generating set used to construction sites may be subject to additional rules and regulations.



**⚠ DANGER**

##### **TOXIC FUMES**

The exhaust of the generating set contains carbon monoxide, Using engine indoors **CAN KILL YOU!**

**NEVER** use inside any building or any kind of enclosure, **EVEN IF** doors and windows are open.

Place the generating set in a well-ventilated and clean area.

Note the wind direction and air current when place the generating set.

##### **High altitude**

This generating set may require a high altitude carburetor kit to ensure correct operation at high altitudes. Consult the authorized local dealer for high altitude kit information if you always operate your engine at altitudes above 5, 000 feet (1,500 meters).

**⚠ CAUTION**

Even with carburetor modification, generating set horsepower will decrease about 3.5% for each 1,000 feet (300 meters) increase in altitude. The effect of altitude on horsepower will be greater than this if no carburetor modification is made.

**⚠ CAUTION**

Operation the engine at altitude below 5, 000 feet (1,500 meters) with modified carburetor may cause the generating set to overheat and result in serious engine damage. Please restore factory specifications of the carburetor at the dealer when using the engine in a low altitude area.

## 2 Operating Condition

Check for loose or damaged parts, signs of oil or fuel leaks, and any other condition that may affect proper operation.

Repair or replace all damaged or defective parts immediately. Repair or replace all damaged or defective parts immediately.

### **⚠ WARNING**

Failing to correct problem(s) before operation could result in property damage, serious injury or DEATH.

Clean the dirt or foreign objects on the surface around exhaust and air intake of generator.

DO NOT move or tip the generating set during operation.

Use generating set only for intended uses. If you have questions about intended use, ask your local dealer.

## 3 Engine oil check

Place the engine on a level surface with engine stopped. Check the engine oil level.

Remove the oil service cover, unplug the dipstick and clean it.

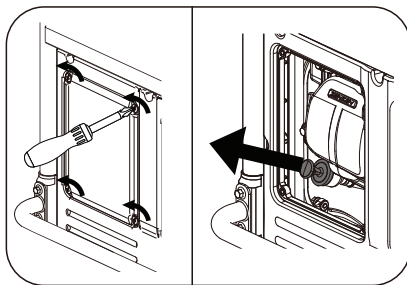

Place the dipstick in the filler neck and stay at the neck of the filler neck.

Remove the dipstick again and check oil level. Level should be between the upper and lower limit.

Fill to the upper limit of the dipstick with the recommended oil if the oil level is too low.

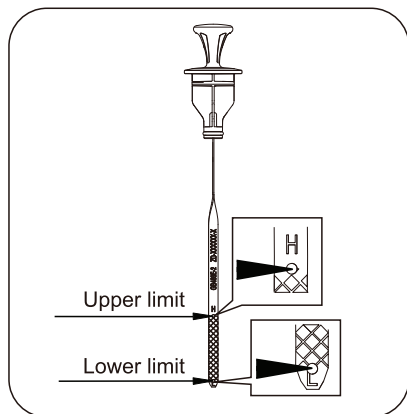

Re-insert the dipstick in place.

Refer to **add oil** instruction in **MAINTENANCE** section for more information.

**Oil capacity(rated): 1.1L**

**Recommended oil model:  
SAE 10W-30**

**⚠ WARNING**

Oil is a major factor affecting performance and service life. Use 4-stroke automotive oil recommended in the **MAINTENANCE** section of this manual.

**⚠ CAUTION**

Operate generating set only on leveled surfaces. The engine is equipped with a low oil sensor (applicable types) that will automatic stop the engine when the oil level falls below the safe limit. To avoid the inconvenience of an unexpected shutdown. Fill to the upper limit and check the oil level regularly.

**⚠ WARNING**

This engine is not filled with oil before send out from the factory. Any attempt to crank or start the engine before it has been properly filled with the recommended type and amount of oil may result in engine damage and void your warranty.

**4 Generating set fuel check**

With the engine stopped, check the fuel level. Refill the fuel tank if necessary.

Use clean, fresh, regular unleaded gasoline.

DO NOT mix oil with petrol . Always wipe up any spilled fuel.

Be sure not to fill above the upper limit mark. Always allow room for fuel expansion.

Place the dipstick in the filler neck and stay at the neck of the filler neck.

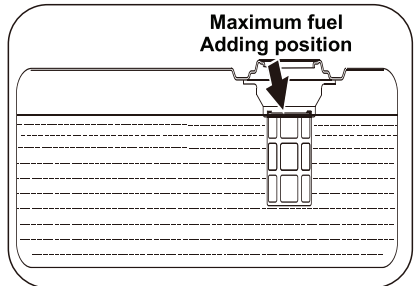

**Fuel capacity (rated):**  
**See parameters.**

**⚠ CAUTION**

Pressure can build up in the fuel tank. Allow the generating set to cool for at least two minutes before removing fuel cap.

Loosen the fuel cap slowly to relieve any pressure in the tank.



**⚠ DANGER**

### **FIRE OR EXPLOSION**

Petrol is highly flammable and extremely explosive.

Keep flammable items away while handling gasoline.

Fill fuel tank outdoors and in a well-ventilated area with the generating set stopped.

Always wipe off spilled fuel and wait until the fuel has dried before starting the generating set.

DO NOT operate the generating set with known leaks in the fuel system. Regularly check if there is any leak on fuel system.

Use proper fuel storage and handling procedures. DO NOT store fuel or other flammable materials nearby.

Keep fire extinguisher handy and be prepared if a fire starts.

**⚠ DANGER**

Do not fill the fuel tank above the upper limit. Over fill will result in engine die or damage the carbon canister (if equipped) and void your warranty.

**⚠ CAUTION**

To minimize gum deposits in your fuel system and to insure easy starting, do not use gasoline left over from the previous season.

NEVER use engine or carburetor cleaner products in the fuel tank or permanent damage may occur.

It is important to prevent gum deposits from forming in essential fuel system parts,

Such as the carburetor, fuel filter, fuel hose or tank during storage. Also, experience indicates that alcohol-blended fuels (called gasohol, ethanol or methanol) can attract moisture, which leads to separation and formation of acids during storage.

Acidic fuel can damage the fuel system of the generating set while in storage. Be sure to review the instructions given in "Storage" section.

Petrol/Alcohol blends: up to 10%alcohol, 90%unleaded petrol by volume is approved as a fuel. Other petrol/alcohol blends are not approved.

Effects of old, stale or contaminated fuel are not warrantable.

## **⚠ CAUTION**

Allow the generating set to cool for at least two minutes before removing fuel cap when adding fuel.

Loosen the fuel cap slowly to relieve any pressure in the tank.

## **5 Generating set grounding**

The generating set must be properly connected to an appropriate ground. It helps prevent electrical shock if a ground fault condition exists in the generating set or in connected electrical devices, especially when the unit is equipped with a wheel kit.

Proper grounding also helps dissipate static electricity, which often builds up in ungrounded devices.



## **⚠ DANGER**

### **Electrical Shock**

Failure to properly ground the generating set can result in electric shock.

A ground terminal has been provided on the generating set.

For remote grounding, connect a length of heavy gauge (4mm<sup>2</sup>) copper wire between the generating set ground terminal and a copper rod driven into the ground.

## **6 Battery connection**

Remove the fixing bolts and the battery maintenance cover, loosen the battery rubber belt, connect the battery terminals to the motor terminals, and then install the battery maintenance cover.

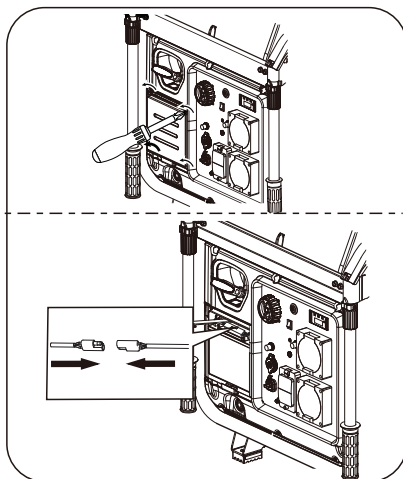

## **7**

Disconnect all electrical devices from the generator and switch off the AC circuit breaker before start the engine.

The generator may be hard to start with electrical devices.

The power draw of the connected electrical equipment cannot exceed the maximum capacity of the generator, please refer to the specification table for details.

## 2. Starting the generating set

### **⚠ WARNING**

When the generator is idle for a long time or improper use or other factors, the battery is undercharging so that the generator cannot be electrically started, follow the manual start steps to control the choke and start the generator manually. The generator will automatically charge the battery during operation.

**1**

Perform Operating checklist and remove all loads.

**2**

Turn the fuel switch to “**FUEL**” position.

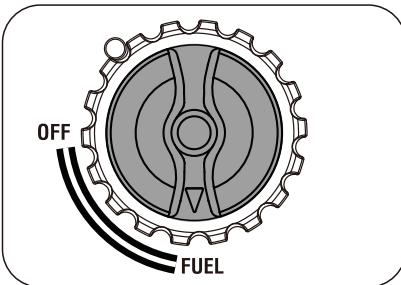

**3**

Turn the start/stop switch to “**RUN**” position.

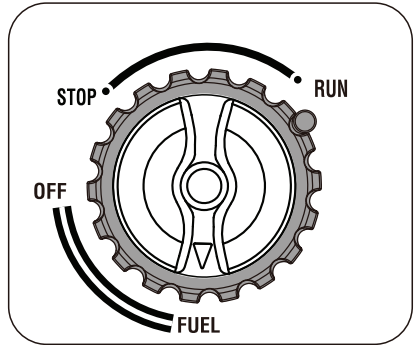

**4**

Select according to the actual configuration of the user

**Electric starting**

1. press the engine switch button to start the engine.

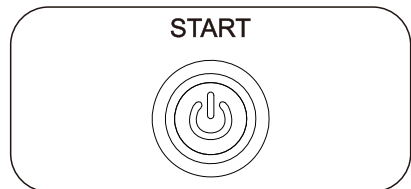

### **⚠ WARNING**

If it fails to start, the generator will restart by itself. If it fails to start after repeated 6 times, please allow the generator to cool for 1 minute and start again.

Sometimes the generator can

take a few attempts to start in cold weather.

If machine does not start in the first 10 seconds, wait for 30 seconds before attempting again.

If the motor turns a little then stops when you press the Start key, it may indicate a low battery. Charge the battery before operation or start by recoil start.

### **CAUTION**

During the operation of the unit, the battery supplies power for the solenoid valve of the carburetor. For this, when the unit is turned off, make sure that the starting switch is in “**STOP**” position and otherwise the storage battery voltage is reduced due to the operating solenoid valve of the carburetor, impacting on starting for next time.

If the engine is equipped with an engine oil alarm, it is possible to prevent engine start when the engine oil in the crankcase is lower than the minimum level.

During running-in, routinely inspect the engine oil. See maintenance section for recommended maintenance period.

## Wireless remote start

### **CAUTION**

If the generator is not used for 24 hours, please press the engine switch to activate it before using the remote key.

1. press and hold the “ON” key for 1 second and release it to start the generator.

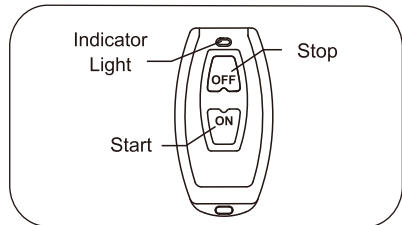

If it fails to start, the generator will restart by itself. If it fails to start after repeated 6 times, please allow the generator to cool for 1 minute and start again.

**NOTE:** Sometimes the generator can take a few attempts to start in cold weather. If machine does not start in the first 10 seconds, wait for 30

seconds before attempting again.

If the motor turns a little then stops when you press the Start key, it may indicate a low battery. Charge the battery before operation or start by recoil start.

### **WARNING**

#### **Remote transmitter and generator learning**

The generator and the remote controller have been successfully matched at the factory, and users do not need to perform matching when use.

#### **Matching wireless remote control (If applicable)**

1. Turn the Start/Stop switch to "RUN" position.
2. Press and hold the learning button until a blue light comes on and then release, the blue light stays on.
3. Press and hold the "OFF" button of the remote control until the learning lamp flashes 1 time and then release it.
4. Press and hold the "ON" button of the remote control until the learning lamp flashes for 1 time and then release.
5. Press and hold the learning button until it goes out and then release it.

#### **Manual start**

When starting engine, grasp the recoil starter handle and pull slowly until resistance is felt. Then pull rapidly to avoid kickback.

### **WARNING**

Check starter cord conditions before operating. Have it replaced immediately by local authorized dealer if cord is frayed.



### **WARNING**

#### **KICKBACK**

Rapid retraction of the starter cord will pull hand and arm towards the engine faster than you can let go.

Unintentional startup can result in entanglement, traumatic amputation or laceration. Broken bones, fractures, bruises or sprains could result.

### **WARNING**

When the battery power of the generator is too low to start the generator, please operate the choke handle as the following figure to start the generator.



## **⚠ CAUTION**

Choke plate should be setting in different width due to temperature and other factors.

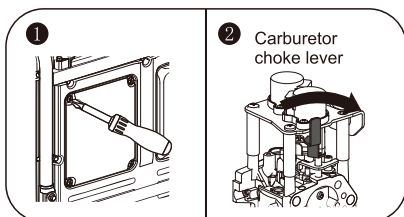

1. Remove the oil maintenance cover.
2. Move the carburetor choke lever to the right to close the choke.
3. When starting engine, grasp the recoil starter handle and pull slowly until resistance is felt. Then pull rapidly to avoid kickback.

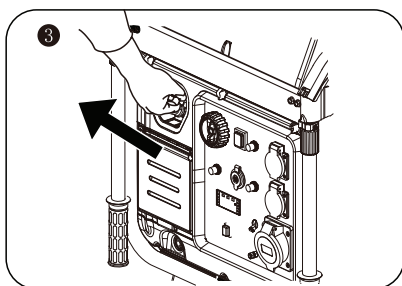

4. After the generator is started, move the carburetor choke lever to the left to open the choke.

4

Carburetor  
choke lever

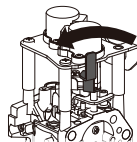

5

After completing the above operations, the generator can be connected to electrical equipment.

## **⚠ CAUTION**

Do not restart the generator without removing the fault. It is strictly forbidden to start the generator after using other batteries without authorization.

## **⚠ WARNING**

It is prohibited to start or close the generating set when the output terminal of generating set is connected to an electric device and the electric device is in "ON" state.

### **3. Connect to electrical devices**

1. Inspect power cord for damage before using. There is a hazard of electrical shock from crushing, cutting or heat damage.

2. Make sure that the generating set has been properly grounded. If the electric devices require grounding, the generating set must ground.
3. Make sure that the electric devices are in “OFF” position.
4. Allow the engine to stabilize and warm up for a few minutes after starting.
5. Connect and start the electric devices.
6. Turn off all electric devices and disconnect them from the generating set.
7. If the generating set supplies for several loads or electric devices, start the smallest one first and the largest one last.



**⚠ DANGER**

**ELECTRICAL SHOCK**

To reduce the risk of electrical shock, DO NOT use electrical cords that are worn, frayed, bare or otherwise damaged.

DO NOT touch bare wires or receptacles.

DO NOT handle generating set or electrical cords while standing in water, while barefoot, or while hands or feet are wet.

**⚠ DANGER**

If connected devices overheat, turn them off and disconnect them from generating set.

**Loading capacity**

**⚠ WARNING**

**DO NOT overload the generating set.**

Exceeding the generating set’s capacity can damage the generating set and/or electric devices connected to it.

You must make sure your generating set can supply enough rated (running) and (starting) watts for the electrical devices at the same time. Follow these simple steps to calculate the running and starting watts necessary for your purposes.

- a. Count the electrical devices you will power at the same time.
- b. The amount of power you need to run with the devices is the total rated (running) watts of these items.
- c. Starting power is the power needed shortly when electric devices start. Since not all devices start at the same time, starting power can be estimated by the maximum power of all devices plus the total power counted in step b.

## Wattage Reference Chart

Electric equipment		Rate power(W)	Starting power(W)
Appliances	Tablet TV 27"	80	100
	Energy saving lamb	5-50	5-50
	Electric cooker	1000	1000
	Computer	250	250
	Electric fan	50	100
	Washing machine	250	500
	Refrigerator	50	300
	Air-conditioner	1600	3200
Electric tooling	Electric hammer	1000	1500
	Impact Hammer	3000	6000
	Water pump	2200	5000
	Electric welding machine	5000	7500
	Air compressor	5000	10000

### **⚠ WARNING**

It is necessary to equip with circuit protector or switch to isolate the generating set from the electric utility when the generating set is mainly used for backup. Failure to isolate the generating set from the power utility may result in injury or death to electric utility workers and damage to the generating set due to back feed of electrical energy.

## 4. Stopping the generating set

**1**

Remove the connectors of all electric equipment from the generating set panel.

### **⚠ WARNING**

NEVER stop the engine with electrical devices connected and running.

**2**

### Suitable for Remote stop

press the "OFF" button on the remote.

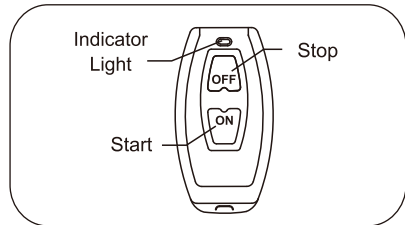

**3**

Turn fuel switch to "OFF" position.

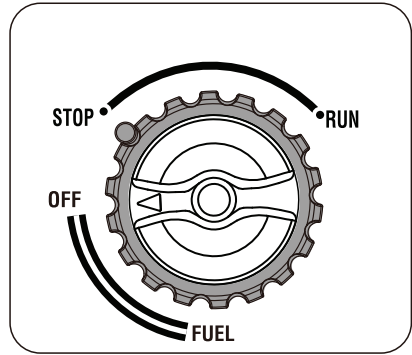
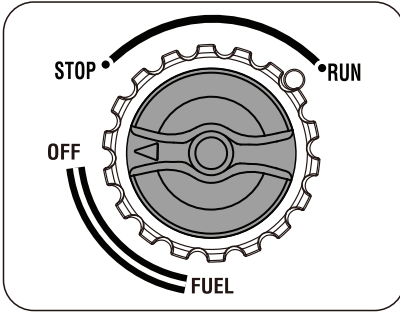

**⚠ WARNING**

**Generator long-term storage:**

If the generator needs to be stored for a long time, please turn the fuel switch to the “**OFF**” position. After the fuel in the carburetor fuel cup is burnt out and the generator automatically stops, turn the start-stop knob to the “**STOP**” position.

If the start-stop switch knob is not placed in the “**STOP**” position, and it is left for a long time, the battery will be depleted of power, making it impossible to start the generator normally.

**4**

Turn the start/stop knob to “**STOP**” position to stop the generator.

## IV. Maintenance

It is the operator's responsibility to complete all scheduled maintenance in a timely manner. Correct any issue before operating the generating set. Always follow the inspection and maintenance recommendations and schedules in this manual.



Accidental starts can cause Severe injury or death. Remove the spark plug cap and ground generating set before performing any service.



Improper maintenance or failure to correct a problem before operation can cause a malfunction and result in property damage, serious injury or DEATH. Improper maintenance will void your warranty.



The filter element may contains PAHs, PAHs are harmful for your health. Please wear gloves for protection during air filter maintenance.

### 1. Maintenance schedule

Stop the generating set before servicing, disconnect all electric devices and battery (If equipped), and cool down the generating set completely.

Serve the generating set in a clean, dry and flat area, so that no accident would happen during the servicing. Please make the wheel in brake state to stop accidental movement of generating set.

Follow the service intervals indicated in the chart below. Service your generating set more frequently when operating in adverse conditions.

Contact your local authorized service dealer for your generating set or engine maintenance needs.

		Each time before use	The first month or 10 hours <sup>note2</sup>	Every three months or 50 hours <sup>note2</sup>	Every six months or 100 hours <sup>note2</sup>	Every year or 300 hours <sup>note2</sup>
Engine oil	Inspection	√				
	Replacement		√		√	
Air filter	Inspection	√				
	Cleaning				√ <sup>note3</sup>	
Spark plug	Inspection and adjustment				√	
	Replacement					√
Spark Extinguisher <sup>note1</sup>	Cleaning				√	
Idle speed	Inspection and adjustment					√ <sup>note4</sup>
Valve clearance	Inspection and adjustment					√ <sup>note4</sup>
Carbon canister <sup>note1</sup>	Inspection	Every two years <sup>note4</sup>				
Low permeability oil tube <sup>note1</sup>	Inspection	Every two years <sup>note4</sup>				
Oil tube	Inspection	Every two years <sup>note4</sup>				

**NOTE :**

Note1: Applicable types (if available).

Note2: Before each season and after then (whichever comes first).

Note3: Service more frequently under severe, dusty, dirty conditions.

Note4: To be performed by knowledgeable, experienced owners or the authorized dealer.

**2. Generating set maintenance**

Use a damp cloth to clean exterior surfaces of the generating set. Use a soft brush to clean the dirt and oil.

Use compressed air (25 PSI) to clear dirt and debris from the generating set.

Inspect all air vents and cooling slots to ensure that they are clean and unobstructed.

**⚠ WARNING**

DO NOT modify the generating set in any way.

DO NOT tamper with the governor.

Generating set supplies correct rated frequency and voltage when running at factory set.

Tampering with the factory set governor will void your warranty.

## **⚠ WARNING**

DO NOT use water to clean the generating set. Water can enter the generating set through the cooling slots and damage the generating set windings.

### **3. Engine maintenance**

#### **Engine oil**

Only use four-stroke engine oil of SJ, SL or equivalent level which are in accordance with or higher than API standard.

Check the API label on oil bottle or other container, and make sure the "SJ, SL" or equivalent level letter is in the label.

SAE 10W-30 is recommended for general, all-temperature use. Other viscosities shown in the chart may be used when the average temperature in your area is within the indicated range.

Recommended Engine Oil Type

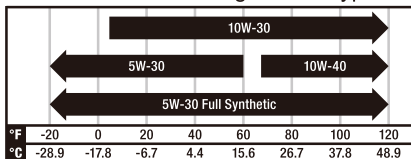

**Ambient temperature**

**Oil capacity (rated):**

**See parameters**

#### **Add oil**

- Place the engine on a level Surface.
- Remove the oil maintenance cover and oil dipstick and wipe oil dipstick clean.

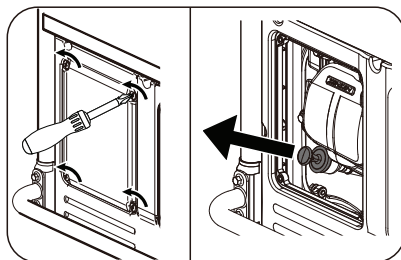

- Add recommended oil to the upper limit.

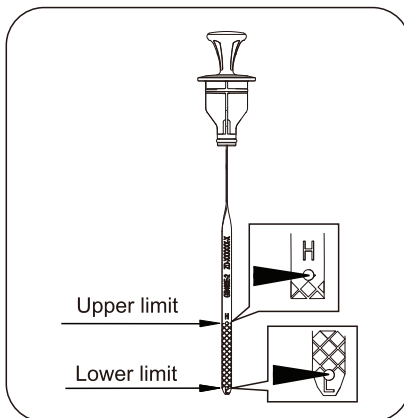

## **⚠ CAUTION**

#### **Oil level check**

Insert the dipstick into filler port and stay at the filler neck. Do not screw the dipstick into the port, then remove the dipstick and check the oil level.

d. Insert the dipstick into its seal position and fix the oil maintenance cover.

e. Properly dispose of any used oil at an approved waste management facility.

### Change oil

#### **⚠ CAUTION**

When the generator is in a hot state, the temperature of the oil is likely to exceed 100°C, and caution should be exercised when changing the oil to prevent burns.

a. Place the generator on a level Surface.

b. Remove the oil drain cover.

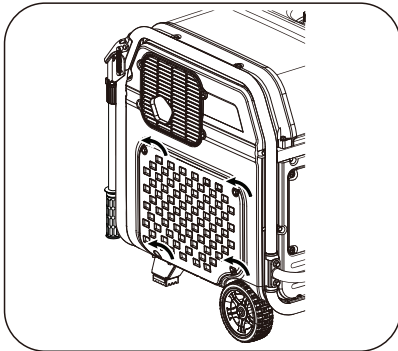

c. Place the oil container box under the oil drain hole of the generator and remove the drain bolt to drain out all the used oil.

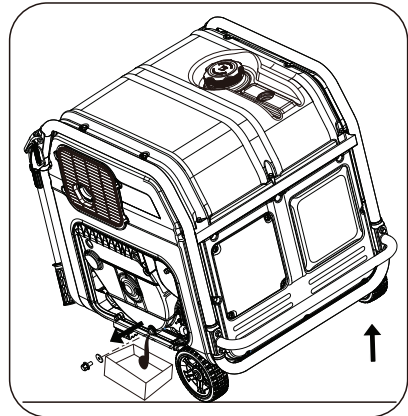

d. fully tighten the drain plug, fix the oil drain cover.

e. Remove the oil maintenance cover.

f. Remove the oil dipstick and add recommended oil to the upper limit.

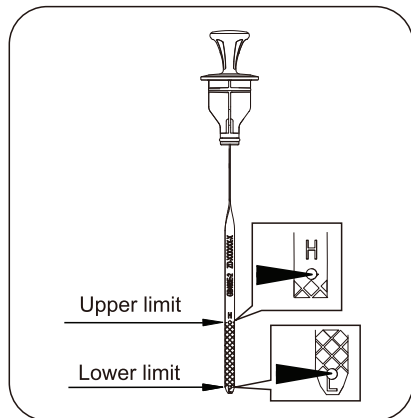

g. Fully insert the dipstick into the oil filling hole and reinstall the oil maintenance cover.

h. Properly dispose of any used oil at an approved waste management facility.



## **⚠ WARNING**

The engine is not filled with oil at the factory. Any operation before it has been properly filled with the recommended type and amount of oil may result in engine damage and void your warranty.

### **Air filter**

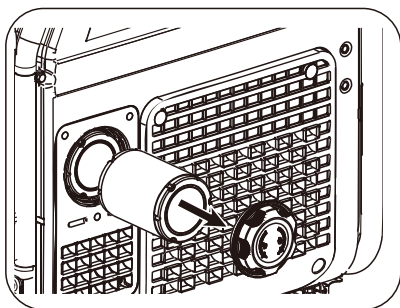

- Unscrew the air filter maintenance cover.
- Take out the air filter element.
- Check whether the paper filter element is damaged, if damaged, please replace it in time.
- Gently tap the filter element to remove the dust or debris attached to the filter element.
- Put the filter element back into the assembly and screw it tightly with the air filter maintenance cover.

## **⚠ WARNING**

DO NOT run the engine without the air filter, or serious danger can result.

### **Spark plug**

- After loosening the fixing bolts, remove the oil maintenance cover.
- Clean the spark plug cap and the impurities around the spark plug hole.
- Unplug the spark plug cap and use a special sleeve to remove the spark plug.
- Observe whether the spark plug and spark plug gasket are damaged, if necessary, replace them.
- Check spark plug gap. If necessary, carefully bend one end of the electrode to adjust the clearance.

### **Spark plug gap: 0.6mm-0.8mm**

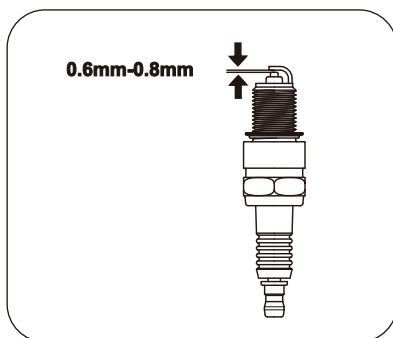

- Carefully thread the plug into the engine **by hand**.

g. After the spark plug is seated, use spark plug wrench to tighten the plug.

### Spark Plug Tighten Torque:

**20-25 N.m**

h. Attach the spark cap to the plug and connect the spark plug wire to the plug.

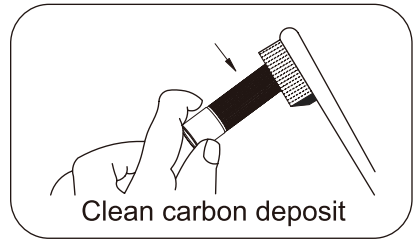

#### **⚠ WARNING**

Only use recommended spark plug or equivalent. DO NOT use spark plugs that have improper heat range.

i. Install Oil maintenance cover.

### Spark Arrester

(Applicable types)

a. Allow the generating set to cool completely before servicing the spark arrester.

b. Remove the anti-stripping bolts before removing the muffler shutters.

c. Remove the set screw, the fixed cover is attached to the end of the spark arrester, and keep it inside the muffler.

d. Carefully remove the carbon deposits from the spark arrester screen with a wire brush.

e. Replace the spark arrester if it is damaged.

f. Reinstall the spark arrester in the muffler and reinstall the muffler blind window.

### Speed

The speed has been pre-set at the factory and should rarely require readjustment. Consult your local authorized dealer for such needs.

#### **⚠ WARNING**

Unapproved adjustment will damage your engine and/or your electrical devices and void your warranty.

### Adjustment

There has no other service and/or adjustment need for your generator.

Unapproved adjustments or tampering can damage your generator and your electrical devices and will void your warranty. Contact your local dealer for such needs.

#### **⚠ WARNING**

Tampering with the factory set governor will damage your generator and void your warranty.

## V. Trouble-shooting

Description of flashing mode of controller status light			
Flashing mode	Flashing mode state	Description	Status
Green light always on		Proper functioning	With output
Green light always on, red light flashing		Overload	With output
Green light off, red light flashes once, and then flashes once every 3 seconds		Overload protection	Without output
Green light off, red light flashes twice, and then flashes twice every 3 seconds		Output short-circuited	Without output
Green light off, red light flashes three times, and then flashes three times every 3 seconds		Inverter overheat	Without output
Green light off, red light flashes four times, and then flashes four times every 3 seconds		Low engine speed	Without output
Green light off, red light always on		Insufficient engine power or other failures	Without output



**NOTES:** The controller fault flashing lights and solutions in the above table can be found in the “Fault View” of the WeChat applet. Other fault flashing lights and solutions not seen in the above table can also be found in the “Fault View” of the WeChat applet. You can also contact Zonsen after-sales service personnel for troubleshooting.

Failure	Trouble	Solution
Generating set fails to start	start/stop switch is in “STOP” or fuel switch is in “OFF”.	Turn start/stop switch to “RUN”, and follow starting procedure to start the generating set . Turn fuel switch to “FUEL”, and follow starting procedure to start the generating set .
	Lack of fuel.	Fill fuel tank per instructions in this manual.
	Lack of engine oil.	Check oil level. This engine is equipped with a low oil sensor. The engine cannot be started unless the oil level is above the prescribed lower limit.
	No ignition.	Remove the spark plug cap. Clean any dirt around the plug base, and then remove the spark plug. Install the spark plug in the plug cap. Turn the start/stop switch to “RUN” position. Grounding the electrode to any engine ground, pull the recoil starter to see if sparks jump across the gap. If there is no spark, replace the plug.  Reinstall the plug and start engine according to instructions in this manual. Consult Customer Service if necessary.
	Spark plug is splashed by fuel	Remove the spark plug and wipe the fuel.
	Battery undercharge (electric start)	Charge the battery by starting the generator manually (at least 30 minutes).
Generating set has no output	Breaker trip	Reset circuit breakers.
	Inadequate cord sets or extension cords.	Check cord sets or extension cords capabilities in section controls. Consult Customer Service if necessary.

## VI. Storage and transportation

### Storage

The generating set should be started at least once every 2 weeks and allowed to run for at least 20 minutes. Follow the instructions below for longer term storage if the generating set will be out of service for 2 months or more.



⚠ DANGER

Fire or explosion

Petrol is highly flammable and extremely explosive.

Empty the fuel tank and shut off fuel valve before storing or transporting this generating set.

1. Allow the generating set to cool completely before storage.
2. Clean the generating set according to instructions in Maintenance section.
3. Drain all fuel completely from the fuel tank, fuel hose and carburetor to prevent gum from forming.
4. Turn the start/stop switch in “STOP” position to cut off the fuel.
5. Drain the oil.
6. Remove the spark plug and pour 15ml fresh oil into the cylinder. Slowly cranking the crankshaft to distribute oil to lubricate the cylinder. Reinstall the spark plug.
7. Disconnect the battery.

8. Please store the generator in a clean, dry area away from direct sunlight.

### Transportation

When transporting or storing the generator for a short period of time, in order to prevent fuel leakage, the generator should be placed in the normal operating position and fixed vertically, the start/stop switch should be in the “OFF” position, the fuel switch should be in the “OFF” position.

⚠ WARNING

When transporting:

Do not overfill the tank. Do not operate the generating set while it is on vehicle. Take the generating set off the vehicle and use it in a well-ventilated place. Avoid a place exposed to direct sunlight when putting the generating set on a vehicle. If the generating set is left in an enclosed vehicle for many hours, high temperature inside the vehicle could cause fuel to vaporize resulting in a possible explosion. Do not drive on a rough road for an extended period with the generating set on board. If you must transport the generating set on a rough road, drain the fuel from the generating set beforehand.

## VII. Specification

### 1. Specification parameter table

Feature		Model	
Engine parameter	Engine model	INV-7500ES	
	Style	OHV, forced cooling, four stroke, single cylinder	
	Displacement (cm <sup>3</sup> )	459	
	Ignition system	TCI	
	Start style	Hand recoil or electric starting	
	Oil capacity(L)	1.1	
Series parameter	Frequency(Hz)	50	60
	Voltage(V)	110,220,230,110/220,115/230, 120/220,120/240	
	Rated power(kW)	7.2	7.2
	Maximum power(kW)	7.5	7.5
	Power factor	1	
	Insulation rate	F	
	Fuel capacity(L)	23	
	Operating temperature(°C)	-10~40	
	Max. site altitude of installation(m)	1500	
	Measured sound pressure level(dB(A))	≤75	
	Measurement uncertainty(dB(A))	≤1.5	
	Guaranteed sound power level(dB(A))	≤96	
	Net weight(kg) (With wheel & handle & rear armrest)	87	

**Note: The generating set with different specification and configurations may have different parameters and may change at any time without notice.**

## 2. Wiring diagram

### BQH9000E Electric starting

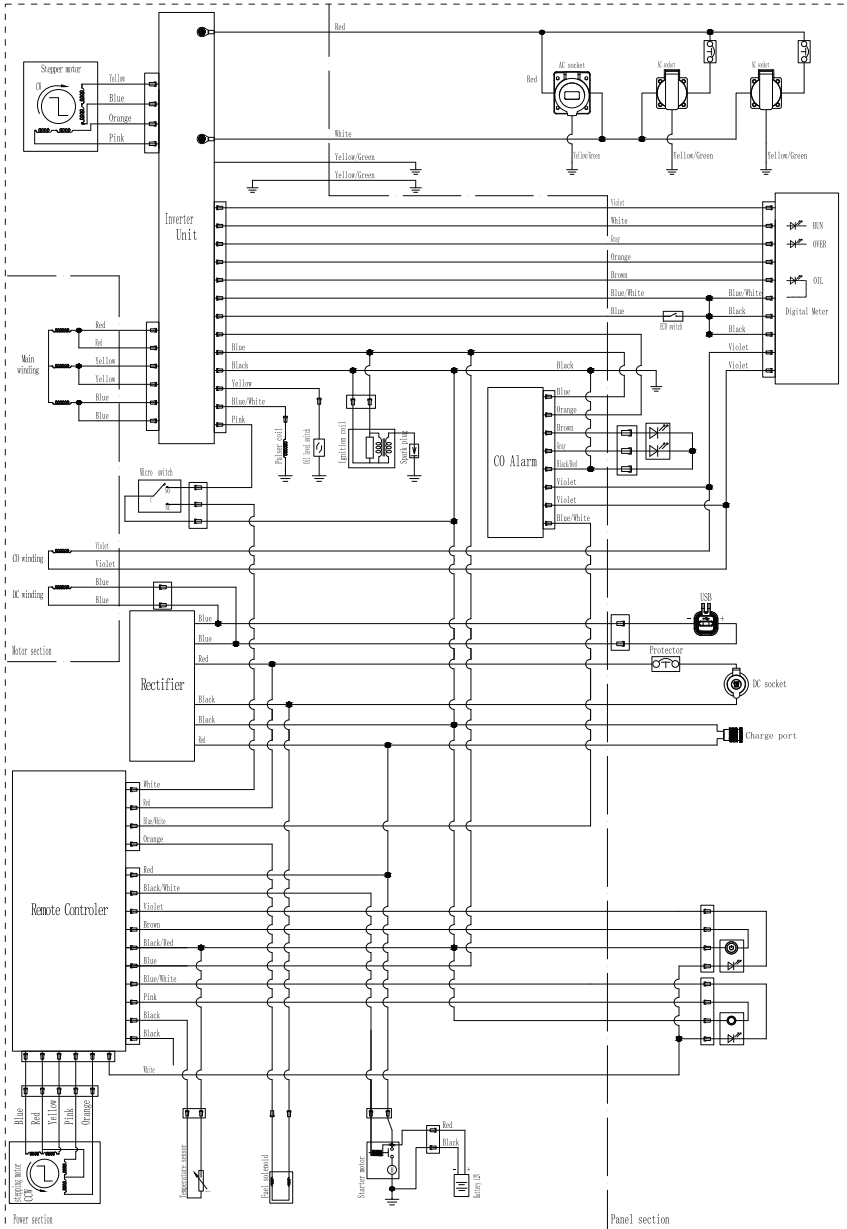

NOTE: Because of the difference of generator, the wiring diagram is only for reference.

**JONO  
&  
JOHNO**



[www.chainsawspares.com.au](http://www.chainsawspares.com.au)

Phone: (03) 5303 0263